

RHD-SERIES

10 000 - 18 000 KG

OPTIMIZED

THE HAGABERG RHD-SERIES IS A PRODUCT RANGE DESIGNED FOR HEAVY TRUCKS

It has been developed at Hagabergs in Sweden, in close cooperation with selected Heavy Trucks teams. This working model gave us the opportunity to get validated information about end-user wishes and requirements. Focus areas during development was to achieve characteristics such as maximum see-through visibility, robust design and highest performance when it comes to reliable operation, low service costs and long service life.

STANDARD MODELS

RHD - forkpositioning and sideshift

RPHD - forkpositioning, sideshift and power pile slope

RHD-L - forkpositioning, sideshift and Lift-Drop fork

OPTIONS

The attachments can be configured with a wide selection of options, that you can find later in this presentation.

Furthermore, with our skilled design engineers at your service and almost endless possibilities for customization, you will be able to meet the most challenging needs.



RHD-SERIES

INTEGRATED FORK POSITIONER
WITH SIDESHIFT

Capacity: 10 000–18 000 kg



FOR HEAVY LOADS AND MAXIMUM VISIBILITY

FEATURES

- Maximum visibility
- High performance
- Heavy-Duty design
- Low service costs

The RHD-series is designed for tough environments. Oversized construction, highest quality of components and protected piping are parts that contribute to make this a heavy-duty attachment. A perfect partner for harsh climates and where there are very high demands on reliable operation. On the other end, you can also benefit from low service costs and long service life.

The forks are roller-mounted using 6 rollers on each fork (4 up and 2 down). The attachment sideshifts easily and gives a precise load handling, even with full load. The visibility for the driver is outstanding, contributing to a safer workplace, a more efficient material handling and reduces the risk for damaging goods.

Model	Capacity / Load centre	Width	Forks	Height	Ground Clearance
	Q / LC kg / mm		A mm		
RHD					
RHD100/254	10000/600	2350	200x90x1600	1050	140
RHD120/254	12000/600		200x90x1600	1050	140
RHD140/254	14000/600		200x100x1600	1100	142
RHD150/254	15000/600		200x100x1600	1100	142
RHD160/254	16000/600		200x100x1600	1100	142
RHD180/254	18000/600		200x100x1600	1100	142
RHD180E/254	18000/900	2450	250x100x2000	1110	150
		2540			
RHD100X/254	10000/1200	2350	200x100x2400	1100	142
RHD120X/254	12000/1200		200x100x2400	1100	142
RHD140X/254	14000/1200		250x100x2400	1110	150
RHD150X/254	15000/1200		250x100x2400	1110	150
RHD160X/254	16000/1200		250x100x2400	1110	150

Note: For other widths, ask for quote.

www.hagaberg.com

RPHD-SERIES

INTEGRATED FORK POSITIONER
WITH SIDESHIFT AND SLOPING
Capacity: 10 000–18 000 kg

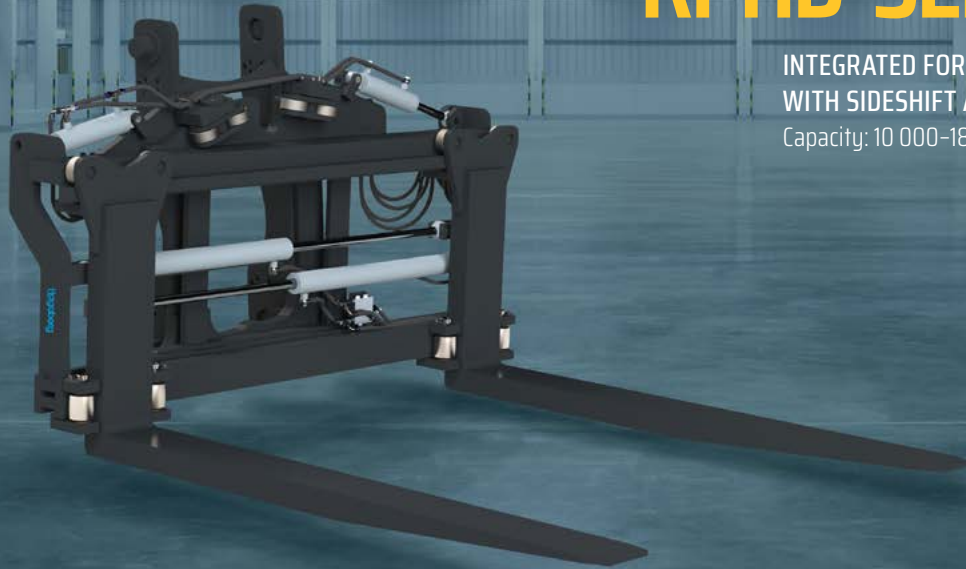

ROBUST WITH POWERED PILE SLOPE

FEATURES

- Maximum visibility
- Sloping function
- High performance
- Heavy-Duty design
- Low service costs

The RHD-series is designed for tough environments. Oversized construction, the highest quality of components, and protected piping are parts that contribute to making this a heavy-duty attachment. A perfect partner for harsh climates and where there are very high demands on reliable operation. On the other end, you can also benefit from low service costs and long service life.

The forks are roller-mounted using 6 rollers on each fork (4 up and 2 down). The attachment sideshifts easily and gives a precise load handling, even with full load. RPHD also has a powered pile slope function which allows “tilt” of ± 5 degrees. The visibility for the driver is outstanding, contributing to a safer workplace, a more efficient material handling and reduces the risk for damaging goods. RPHD is an excellent choice for the wood industry and where you have a rugged terrain.

Model	Capacity / Load centre	Width	Forks	Degrees of Slope	Height	Ground Clearance		
	Q / LC kg / mm						A mm	WxTxL
RPHD								
RPHD100/254	10000/600	2350	200x90x1600	± 5	1050	140		
RPHD120/254	12000/600		200x90x1600		1050	140		
RPHD140/254	14000/600		200x100x1600		1100	142		
RPHD150/254	15000/600		200x100x1600		1100	142		
RPHD160/254	16000/600		200x100x1600		1100	142		
RPHD180/254	18000/600		200x100x1600		1100	142		
RPHD180E/254	18000/900		2450		250x100x2000	1100	150	
			2540					
RPHD100X/254	10000/1200		2540		200x100x2400	± 5	1100	142
RPHD120X/254	12000/1200				200x100x2400		1100	142
RPHD140X/254	14000/1200	250x100x2400		1100	150			
RPHD150X/254	15000/1200	250x100x2400		1100	150			
RPHD160X/254	16000/1200	250x100x2400		1100	150			

Note: For other widths, ask for quote.



Linde H160 with Hagaberg RHD



RHD-L-SOLUTION

INTEGRATED FORK POSITIONER
WITH SIDESHIFT AND LIFT-DROP FORK
Capacity: 10 000–18 000 kg

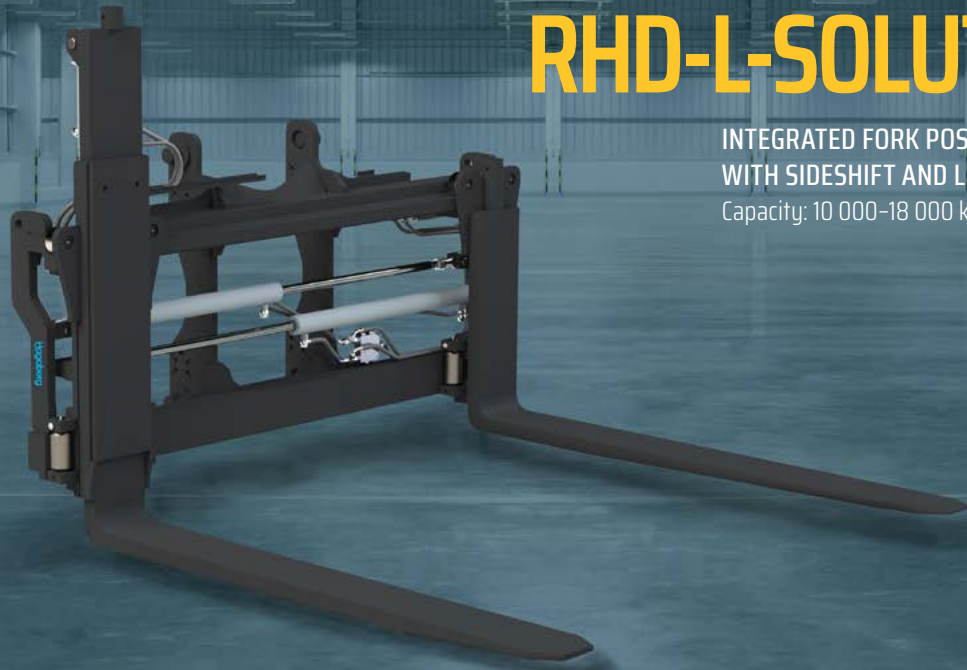

MAXIMUM VISIBILITY AND LEVELLING FORK

FEATURES

- Maximum visibility
- Levelling fork
- High performance
- Heavy duty design
- Low service costs

RHD-L is a system solution, a combination of a RHD-series fork positioner and a Lift-Drop fork, that gives the ability for level compensation. This solution is an alternative to the power pile slope positioner and allows levelling of ± 100 mm. You can choose to have the levelling fork to be installed on the right or on the left side. Furthermore, we offer both 1- and 2-cylinder alternatives.

The 1-cylinder alternative gives maximum protection of the hydraulic cylinder, and is normally the first hand choice. The 2-cylinder alternative comes in play when you have limitations by a ceiling or other structure, where you need to keep the height of the Lift-Drop fork as low as possible.

The Lift-Drop fork will allow you to compensate if you have an uneven surface or if the goods are not balanced on the forks.

Model	Capacity / Load centre	Width	Forks	Levelling	Height	Ground Clearance
RHD-L-SOLUTION						
RHD-L100/254	10000/600		200x90x1600		1050	140
RHD-L120/254	12000/600		200x90x1600		1050	140
RHD-L140/254	14000/600		200x100x1600		1100	142
RHD-L150/254	15000/600		200x100x1600		1100	142
RHD-L160/254	16000/600		200x100x1600		1100	142
RHD-L180/254	18000/600	2350	200x100x1600		1100	142
		2450				
RHD-L180E/254	18000/900	2540	250x100x2000	± 100	1110	150
RHD-L100X/254	10000/1200		200x100x2400		1100	142
RHD-L120X/254	12000/1200		200x100x2400		1100	142
RHD-L140X/254	14000/1200		250x100x2400		1110	150
RHD-L150X/254	15000/1200		250x100x2400		1110	150
RHD-L160X/254	16000/1200		250x100x2400		1110	150

Note: For other widths, ask for quote.

ADAPPTIONS



FORKS

We offer a complete range of forks for heavy trucks. These are used in a number of industries and applications such as lumber yards, prefab-house manufacturing, ports, steel industry, mining- and stone industry.

Our range of forks comes with different tapering length, width, thickness, tip, material, coating etc.



CAMERAS AND SENSORS

Hagaberg offers two product lines with system solutions for camera and sensor technology.

SmartFork® where the sensor technology is integrated in the forks and HCB™ where the system is mounted on the outside of the forks or on the attachment frame



KOOI® REACHFORKS

Hydraulic telescopic forks for loading/unloading and handling goods of varying lengths. Available for all sizes of trucks, both for indoor and outdoor use. The telescopic forks are integrated in the fork positioners and can be equipped with both cameras and a range of accessories that make work more efficient.



CARRIERPLATES / AND QC6

CarrierPlates give you the ability to switch between hook on forks and hook-on attachments, all with ISO- or TWS-hooks. QC6 is a manual quick coupling system with CarrierPlates that also includes hydraulic quick couplings.



LOAD BACKREST

All our fork positioners can be equipped with load backrests with various design options. For example different heights and with bend on top. There are also options for fork mounting.



CUSTOMIZED SOLUTIONS

Multi-pallet attachments, coil booms, rotating attachments, unique functional solutions, challenging requirements and limitations, etc. is everyday for our experienced engineers.

Hagaberg

RELIABILITY + INNOVATION

Hagaberg provides solutions that help companies work more safely and efficiently with material handling. We are driven by the design and manufacture of fork positioners and system solutions tailored to both the forklift and the user's specific application. Our shared focus is always to deliver the market's best products and customer service.

Phone: +46 583 57 44 40
E-mail: info@hagaberg.com
Website: www.hagaberg.com