

FORK POSITIONERS

EFFECTIVE AND ADAPTED POSITIONERS

1 - 18 TONNES

OPTIMIZED

Hagaberg specializes in hydraulic fork positioners with integrated sideshift. Choose a model based on your needs of machine type, lifting capacity, width, operating environment, etc.

Our products are designed with maximized visibility for the driver, which increases workplace safety and reduces the risk of damaged goods. The positioners are characterized by robust construction with high performance, long service life, and excellent reliability. The hydraulics are routed with pipes/hoses and positioned to be protected from possible damage.

Hagaberg positioners can be mounted on all types of forklifts, construction machinery, and tractors, both new and used. Installation is primarily done through integration, but we also offer HOOK-ON, machine brackets, and a range of quick couplers.

As standard, our units are delivered with standard forks or CarrierPlates that are adapted to carry ISO-/TWS forks or other attachments. We have a wide range of forks and options to customize the positioner for your specific application.

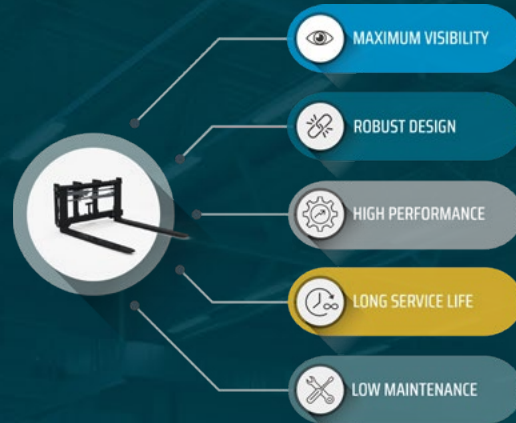

RANGE OVERVIEW

	1.6	2.5	3.5	5.0	5.0E	6-8	10-18	Reach Truck
	1.6 t / 500 mm 1.2 t / 600 mm	2.5 t / 500 mm 2.0 t / 600 mm	3.5 t / 500 mm 3.0 t / 600 mm	5.0 t / 500 mm 4.0 t / 600 mm	5.0 t / 600 mm	6-8 t / 600 mm 6-8 t / 900 mm 6-8 t / 1100 mm	10 - 18 t / 600 mm 18 t / 900 mm 10 - 16 t / 1100 mm	1-3 t / 600 mm
C - Series								
C	x	x	x	x	x	x		
COC	x	x						
CR								x
E - Series								
E	x	x	x	x	x	x		x
E-MARINE		x	x					
F - Series								
F						x		
F45						x		
RHD - Series								
RHD							x	
RPHD							x	
RHD-L							x	
HEC/HEF - Series								
HEC		x	x	x				
HEF		x	x	x				

NOTE: Other models and capacities are offered on request.

C-SERIES

INTEGRATED FORK POSITIONER WITH SIDESHIFT

Capacity: 1 600 – 8 000 kg
Width: 950 – 2 500 mm



HIGH PERFORMANCE AND CLAMPING

FEATURES

- Powerful all-round unit
- Light clamp handling
- High residual capacity
- Low maintenance
- Excellent visibility

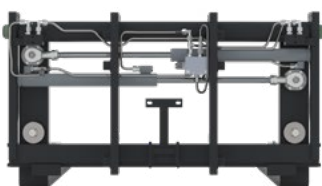
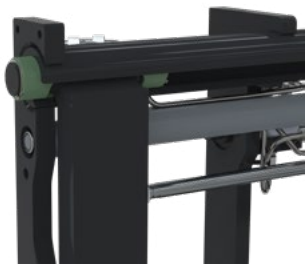

C-SERIES

The C-series is one of our smartest attachments. The unique C-profile design provides excellent visibility for the driver, contributing to safer handling of goods and a safer workplace. Additionally, the unit enables lighter clamp handling, and weighs less than comparable designs.

The attachment has been designed for demanding applications and the additional support wheel on the back of the forks permits a smooth and soft sideshift even with a full load. Self-lubricating bushings reduce the need for maintenance and easy access makes the replacement of spare parts swift.

The product family consists of several series:

COC-SERIES

When loading and unloading trucks, the goods are often placed along the sidewall of the truck and the forks are used to push it in place. This might damage the attachment as well as the truck and the goods. With COC the pallets can be shideshifted outside the frame, which makes loading and unloading easy, smooth, and timesaving.

Adapted for warehouse and terminal

Capacity: 1 600 – 2 500 kg
Width: 950 – 1 200 mm

CR-SERIES

The CR-series is specially designed for reach trucks with a capacity from 1 200 – 3 000 kg with LC 600 mm. The CR-series can also be delivered as a tilting attachment, with or without tilt cylinder.

Adapted for reach trucks

Capacity: 1 200 – 3 000 kg
Width: 750 – 1 300 mm

E-SERIES

INTEGRATED FORK POSITIONER WITH SIDESHIFT

Capacity: 1 600 – 8 000 kg
Width: 750 – 2 200 mm



EXCELLENT IN DIRTY ENVIRONMENTS

FEATURES

- Suitable for dirty environments
- Precise positioning of the forks
- Silent operation
- Good visibility

E-SERIES

With the E-series you get a Pin-type unit. This means that the forks hang on a pin in the unit. With encapsulated, high-quality bearings, it is especially suitable for dirty environments and allows sideshifting with full load. The design also offers high performance in terms of precise positioning and noiseless operation.

The product family consists of several series:

E-SERIES MARINE

E-Marine is modified to have an increased resistance to the corrosive effects of salt water. All sensitive parts have been upgraded to withstand continuous exposure. There is a special chrome layer on the pin (bar), high-resistance encapsulation on the high-quality bearings, stainless steel support rollers, and special screws sealed with marine silicone.

For corrosive environments

Capacity: 1 600 – 3 500 kg
Width: 990 – 1 600 mm

Specialized salt water resistant paint is used for all painted parts such as the frame and the hydraulic pipes. Some parts are also galvanized before painting.



F-SERIES

INTEGRATED FORK POSITIONER WITH SIDESHIFT

Capacity: 6 000 – 8 000 kg
Width: 1 400 – 2 500 mm



RELIABLE OPERATION AND MAXIMUM VISIBILITY

FEATURES

- Built for heavy loads
- Suitable for very dirty environments
- Protected piping
- Maximum visibility

F-SERIES

The F-series is constructed for tough environments and where there are very high demands on the positioners. The forks are roller-mounted using 6 rollers on each fork (4 up and 2 down).

The attachment sideshift easily and smoothly even with heavy loads. The visibility for the driver is outstanding, making work safe and secure.

The product family consists of several series:

F4S-SERIES

F4S also has a powered pile slope function which allows "tilt" of $\pm 4-5$ degrees. F4S is an excellent choice for the wood industry and where you need to compensate for uneven terrain or goods that are difficult to balance.

With powered pile slope

Capacity: 8 000 kg

Width: 1 800 – 2 500 mm

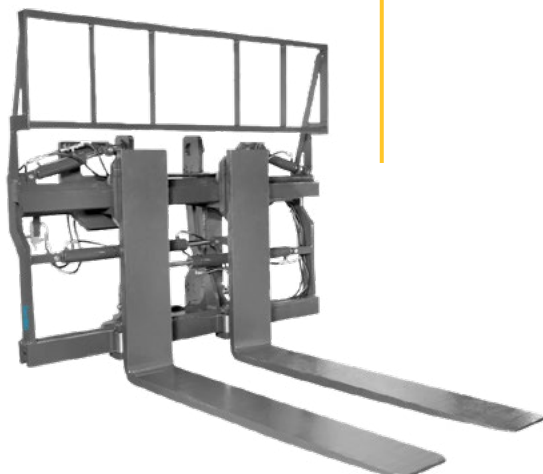

RHD-SERIES

INTEGRATED FORK POSITIONER WITH SIDESHIFT

Capacity: 10 000 – 18 000 kg
Standard width: 2 540 mm



FOR HEAVY LOADS AND MAXIMUM VISIBILITY

FEATURES

- Maximum visibility
- High performance
- Heavy-Duty design
- Low service costs

RHD

The RHD-series is designed for tough environments. Oversized construction, the highest quality components, and protected piping are parts that contribute to making this a heavy-duty attachment. A perfect partner for harsh climates and where there are very high demands on reliable operation. On the other end, you can also benefit from low service costs and long service life.

The forks are roller-mounted using 6 rollers on each fork (4 up and 2 down). The attachment sideshifts easily and gives precise load handling, even with a full load. The visibility for the driver is outstanding which contributes to a safer workplace, more efficient material handling, and reduces the risk of damaging goods.

The product family consists of several series:

RPHD

ROBUST WITH POWERED PILE SLOPE RPHD has a powered pile slope function which allows sloping of ± 5 degrees. RPHD is an excellent choice for the wood industry and where you need to compensate for uneven terrain or goods that are difficult to balance.

With powered pile slope

Capacity: 10 000 – 18 000 kg
Standard width: 2 540 mm

RHD-L

MAXIMUM VISIBILITY AND LEVELLING FORK RHD-L is a system solution, a combination of an RHD-series fork positioner and a Lift-Drop fork, that gives the ability for level compensation. This solution is an alternative to the power pile slope positioner and allows levelling of ± 100 mm. We offer both 1- and 2-cylinder alternatives.

With levelling fork

Capacity: 10 000 – 18 000 kg
Standard width: 2 540 mm

The 1-cylinder alternative gives maximum protection of the hydraulic cylinder and is normally the first-hand choice. The 2-cylinder alternative comes into play when you have limitations by a ceiling or other structure, where you need to keep the height of the Lift-Drop fork as low as possible. The Lift-Drop fork will allow you to compensate for uneven terrain or goods that are difficult to balance.

HEC / HEF-SERIES

HOOK-ON FORK POSITIONER WITH SIDESHIFT

Capacity: 2 000 – 5 000 kg
Width: 1 000 – 1 450 mm



POSITIONER ON STOCK

FEATURES

- Always in stock
- High performance and secure operation
- Good visibility
- Fits all trucks
- Easy installation

The HE series is a fork positioner with positioning and sideshift that fits the majority of trucks in the European market. The attachment comes in two versions. HEC is equipped with CarrierPlates that allow the use of standard ISO forks whereas HEF is delivered with integrated forks.

The attachments have encapsulated, high-quality bearings, that are especially suitable for dirty environments. The Pin-type models offer precise positioning and noiseless operation. The forks and CarrierPlates are equipped with support rollers that allow sideshifting with full load. ISO brackets on the back of the positioners allow them to be mounted directly onto the existing fork carriage. The range consists of 24 models, of which 8 are available in stock for immediate delivery. The capacity range extends from 2 000 kg up to 5 000 kg.

ADAPTIONS

Forks

All positioners can be equipped with forks in other dimensions, materials, coatings, etc.

CarrierPlates and QC6

CarrierPlates give you the ability to switch between hook on forks and hook-on attachments, all with ISO- or TWS-hooks. QC6 is a manual quick coupling system with CarrierPlates that also includes hydraulic quick couplings.

Cameras and sensors

Hagaberg offers two system solutions with camera and sensor technology. SmartFork® with integrated camera- and sensor systems, and HCB™ where the system is mounted on the outside of the forks or on the frame.

Load backrest

All our fork positioners can be equipped with load backrests with various design options. For example, different heights and with bend on top. There are also options for fork mounting.

KOOI®Reachforks

Hydraulic telescopic forks for loading/unloading and handling goods of varying lengths. Available for all sizes of trucks, both for indoor and outdoor use. The telescopic forks are integrated in the fork positioners and can be equipped with both cameras and a range of accessories that make work more efficient.

Customized solutions

Multi-pallet attachments, coil booms, rotating attachments, unique functional solutions, challenging requirements, limitations, etc. are customary for our experienced engineers.

Hagaberg

RELIABILITY + INNOVATION

Hagaberg provides solutions that help companies work more safely and efficiently with material handling. We are driven by the design and manufacture of fork positioners and system solutions tailored to both the forklift and the user's specific application. Our shared focus is always to deliver the market's best products and customer service.

Phone: +46 583 57 44 00
E-mail: info@hagaberg.com
Website: www.hagaberg.com