



Hagaberg

RELIABILITY + INNOVATION

EXPERTS IN INTEGRATED FORK POSITIONERS
FOR FORKLIFT TRUCKS

MADE IN
SWEDEN

Hagaberg develops, manufactures, and markets forklift attachments and related system solutions for forklift trucks.

The core products are integrated fork positioners for forklift trucks. Our construction offers maximum visibility for the driver, increasing workplace safety and making our positioners an excellent choice for forklifts and construction machinery.

Our extensive range includes integrated fork positioners with capacities from 1 to 25 tons, also available as hook-on versions. Furthermore, we offer the OilQuick® automatic quick coupler system - OQT, as well as Cebriá's complete range of rotators, clamps, and more. We also provide mast remodeling, including masts, hose packages, and various accessories. In addition, we manufacture masts and integrated mast-and-attachment solutions for AGVs and forklift trucks.

With the support of our in-house engineers, we collaborate closely with customers and end users to develop optimized material handling solutions with regard to function, safety, and productivity. We offer both adaptations of our standard products and fully customized solutions developed from square one.



Hagaberg

RELIABILITY + INNOVATION

"RELIABILITY + INNOVATION" is at the heart of Hagaberg's brand.

MADE IN
SWEDEN

RELIABILITY

QUALITY

Quality does not come by itself. It is consistently achieved through stringent standards, intelligent execution, focus, creativity, and expert craftsmanship.

Our products are robust, featuring durable components, such as durable, self-lubricating bushings, ensuring extended lifespan and reduced maintenance costs. Our products are manufactured in Sweden, with all subcontractors and suppliers located exclusively in Sweden or Western Europe.

CORE COMPETENCE

We are proud to have all our development and manufacturing in Sweden. With this, we ensure, among other things, access to skilled and committed engineers. Engineers with the ability to enforce our business concept to offer products with the highest performance in terms of quality, function, and safety.

SAFE PROCESSES

Our core process is welding, where we're certified for both methods and quality. We are also supported in our everyday work and our total processes by both quality and environmental management systems.

At Hagaberg, we sleep well at night. With the industry's most knowledgeable and most dedicated staff, we know that we will always create the best and most innovative products.

INNOVATION

For us, innovation is about transforming and refining ourselves through new ideas, methods, and products. It can range from small, unique improvements in our production processes to rethinking regarding services in connection to the delivery of our attachments. The most important is to constantly increase customer value in what we provide.



SAFE WORKING ENVIRONMENT

Our approach to a safe working environment encompasses both the operator and the individuals around the machine and its direction of travel. The positioners are designed to provide perfect visibility for the operator, increasing safety in the workplace. Good visibility also reduces the risk of collision damage to goods, warehouse fixtures, trucks, gates, etc.

However, in certain applications and environments, smart additional features are required to further enhance safety. Hagaberg offers a unique range of optional products and accessories that can be added into the final solution. Fork cameras, laser indicators on the fork blades, load weight control, and various types of hydraulic and manual telescopic forks are just a few of the products that can be added to achieve an optimized and safe solution.

RANGE

All positioners are characterized by robust designs with high performance, long lifespan and exceptional operational reliability.

C-PROFILE POSITIONERS

The C-series is one of our smartest attachments. The unique C-profile design gives excellent visibility for the driver and contributes to more safe handling of the goods. Furthermore, this model offers lighter clamp handling, and its weight is lower than the corresponding designs.

PIN-TYPE POSITIONERS

With encapsulated, high-quality bearings, it is especially suitable for dirty environments and allows sideshifting with full load. The design also offers high performance in terms of precise movements and quiet operation.



ADAPTIONS

ENVIRONMENTS

We adapt our attachments for different environments where special conditions prevail, such as high heat radiation, low freezing temperatures, corrosion, extreme wear, etc.

SMARTFORK®

A product line of forks with integrated cameras and sensors for visibility, attention, fork positioning and load detection.

FORKS

We offer forks with various functions, such as hydraulic telescopic forks, coatings, designs for specific lifts, as well as a variety of special forks.

CUSTOMIZED SOLUTIONS

Adapt and accessorize the fork positioner to meet your specific needs. And when the application is unique, we offer nearly limitless resources for fully customized solutions.

ROLLER-MOUNTED POSITIONERS

The forks are roller-mounted using 6 or 10 rollers on each fork. The attachment sideshifts smoothly and precisely even at full load and allows lighter clamp handling. The visibility for the driver is one of the best on the market, contributing to safer and more efficient material handling.

L-PROFILE POSITIONERS (CONSTRUCTION MACHINERY)

The attachment is adapted for wheel loaders where the forks slide on the upper and lower beams, and visibility for the driver is very good. The hoses and hydraulic cylinders are completely protected behind the upper beam.

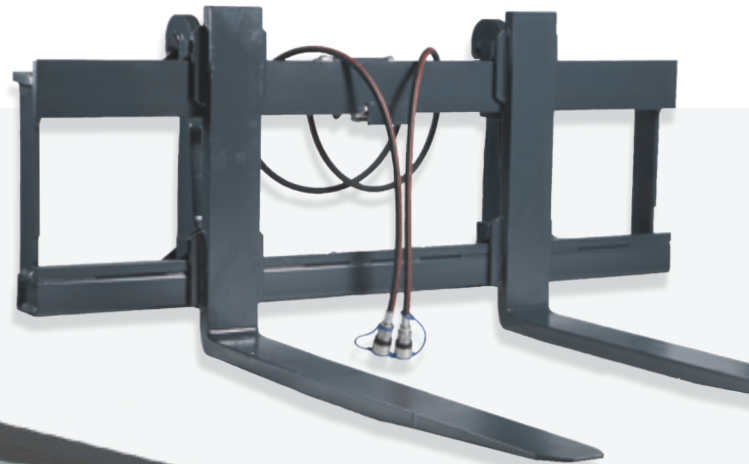
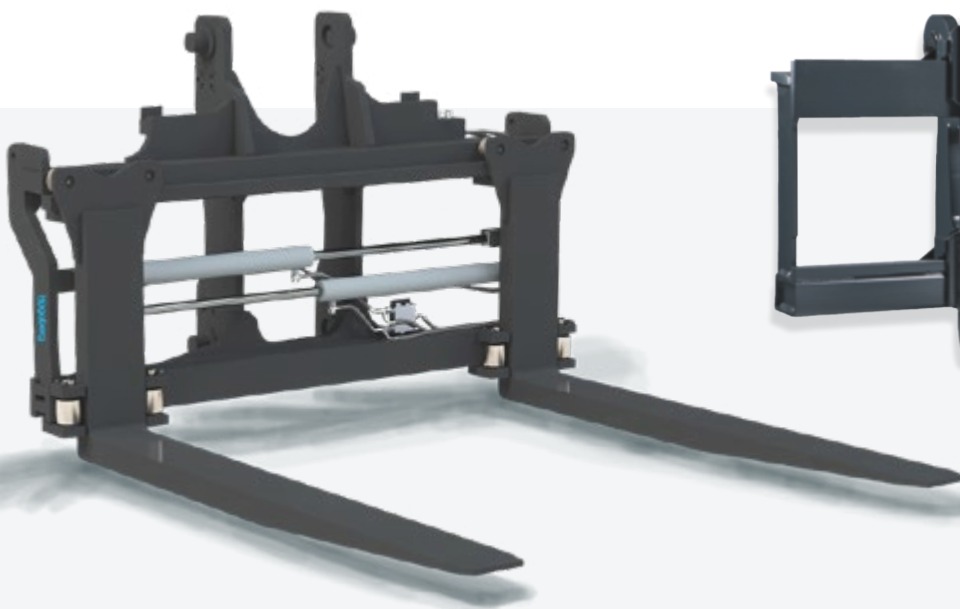

OEM

Hagaberg operates across Europe, where our development takes place in close collaboration with customers and end-users. Our focus is on deliveries to forklift truck production lines and local workshops, where our units are integrated into the forklift's mast.

We are a supplier of high-quality products, where our customer wants to ensure that the attachments improve end-user productivity, have low maintenance costs, and can withstand continuous use in demanding environments. Additionally, our products support and enhance the overall effort towards safer workplaces and reduced environmental footprint.

MILESTONES

- 2026** • Implementation of a new robotic welding cell for frames, forks & masts
- 2024** • Opens sales office in Denmark
- 2023** • Opens sales office in Finland
- 2021** • Relocates HQ and production to new premises in Askersund
- Acquires Bodins Maskin AB
- 2019** • Opens sales office in Poland
- 2013** • Acquires Vaggerys Attachment AB
- 2012** • Caladrius Holding AB new owner
- Main supplier of integrated fork positioners to Fritz Milenz Försäljnings AB (now Linde MH Sweden)
- 1997** •
- 1994** • Design protection C-profile positioners
- 1984** • Founded on family estate Hagaberg outside Kumla

MARKETS / LOCATIONS

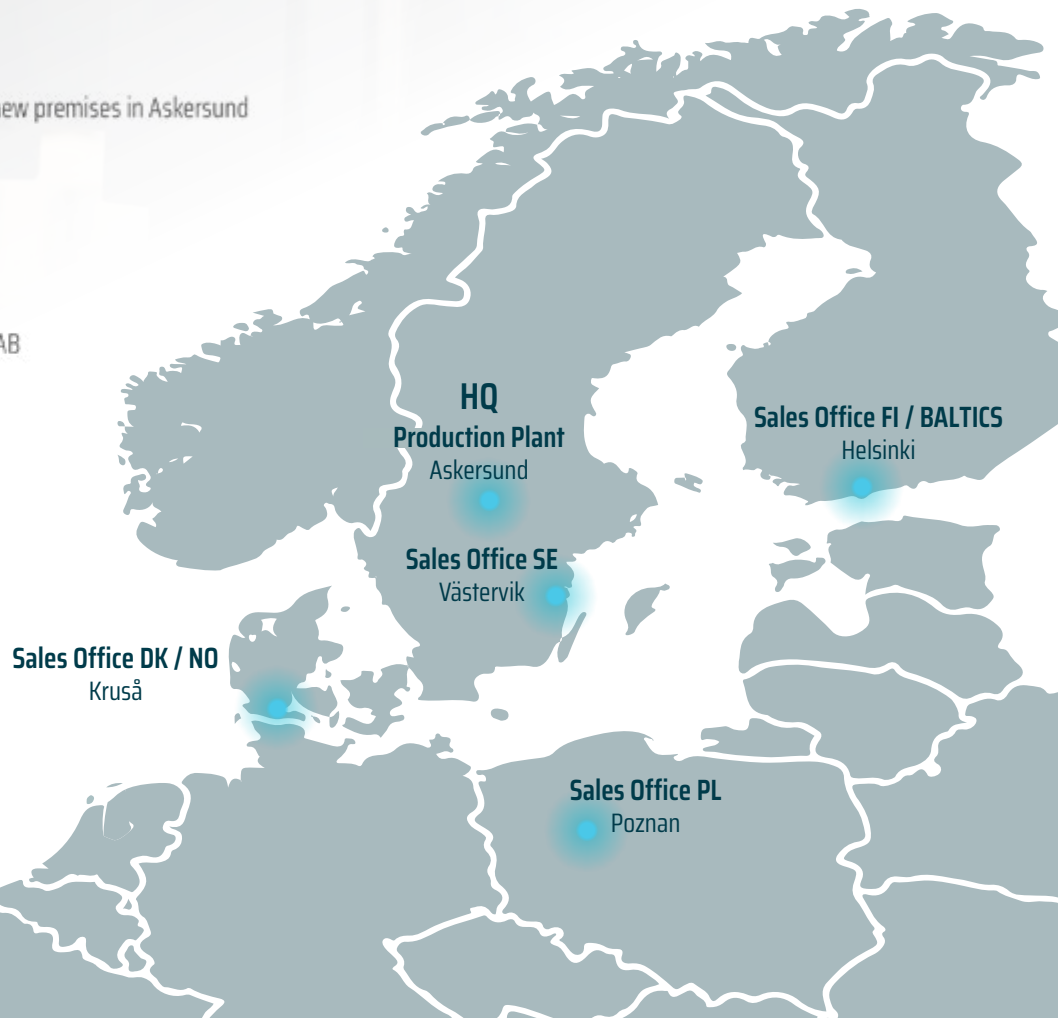



STRATEGIC PARTNERSHIPS



Hagaberg has a strategic partnership with OilQuick® on fully automated quick couplers for forklifts - OQT. The collaboration means that Hagaberg is furthering development and manufacturing of OQT, as well as marketing the range across Europe.

OilQuick is an advanced quick coupler system for forklift trucks and can be supplied in various models for machines from 1 to 9 tons. The operator can change between various hydraulic and mechanical attachments within a few seconds, such as fork positioners, paper roll clamps, rotators etc.



An exciting collaboration that complements the product portfolio with rotators, clamps, multi-fork positioners, telescopic fork positioners, and push/pull attachments, making Hagaberg a full-service supplier.

There is a wide standard range available as well as designing and manufacturing of customized solutions.

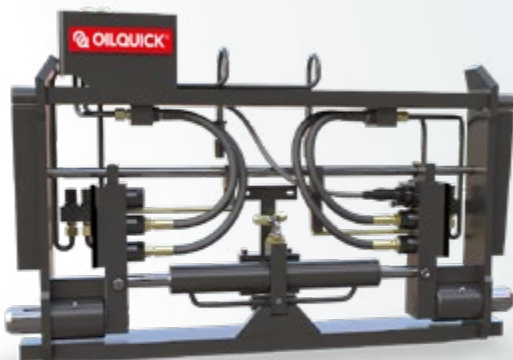

Hagaberg

Hagaberg provides solutions that help companies work more safely and efficiently with material handling. We are driven by the design and manufacture of fork positioners and system solutions tailored to both the forklift and the user's specific application. Our shared focus is always to deliver the market's best products and customer service.

Phone: +46 583 57 44 00
E-mail: info@hagaberg.com
Website: www.hagaberg.com